

Fig. 1: Eight-channel mixed-signal oscilloscopes provide comprehensive measurement and analysis capabilities for embedded, automotive, power and mechatronics applications

Keeping Pace

Clive Davis, Kelvin Hagebeuk and Hafeez Najumudeen discuss how instruments can evolve to meet the latest automotive challenges

The increased use of advanced electronic technologies in modern cars poses considerable challenges to the test and measurement engineer, both at the design debugging stage and for general-purpose performance and maintenance purposes. The modern motor vehicle may contain sophisticated embedded systems linked with the engine control unit as well as serial buses for communications information and control signals throughout the vehicle.

In addition, measurements also need to be made on physical parameters from mechanical elements such as motors and actuators and their interaction with multiple control signals, which can include analogue, digital and high-power content.

Recent developments have led to modern test and measurement instruments aiding engineers in automotive electronic developments. First, the debugging and test of the embedded electronics in engine control units is greatly facilitated by

the use of mixed-signal oscilloscopes with increased channel count; and, secondly, recent developments in the kers (kinetic energy recovery system) technology used in modern racing cars has led to the need for high-accuracy power measurements.

ECUs

Traditionally, the general-purpose test instrument of choice has been the oscilloscope, which has evolved from the early analogue instruments to high-speed digital oscilloscopes with built-in storage and processing capabilities. In recent years, the emergence of mixed-signal oscilloscopes (MSOs) has enabled users to look at analogue and digital signals together on the same display, allowing the interaction between the different types of signal to be examined in depth as an aid to determining the cause-and-effect sequence when problems occur.

However, the first generation of MSOs suffered from a limitation in some applications in that they only

had four measurement channels, which is proving insufficient to address the challenges presented by today's automotive electronic systems. An increasing number of oscilloscope users are finding that the traditional four channels that have been the norm for decades are no longer sufficient. True, there are instruments available that provide eight or more channels, but these are normally oscillographic recorders which do not offer sufficiently high bandwidth and sampling rate.

Some users have created eight-channel set-ups by combining two four-channel oscilloscopes, but this approach requires the instruments to be synchronised: something that is only normally possible in tightly controlled laboratory conditions.

In the words of one automotive electronics engineer involved in developing ECUs: "We need to observe the waveform details of more than four channels of engine control unit signals, along with sensor signals giving us parameters such as rotational speed, fuel injector pulse times and crank angles, to name just a few."

Not only are more IO signals used as the control system becomes more sophisticated and complicated, there is also a need for faster sampling and higher bandwidth because of the noise

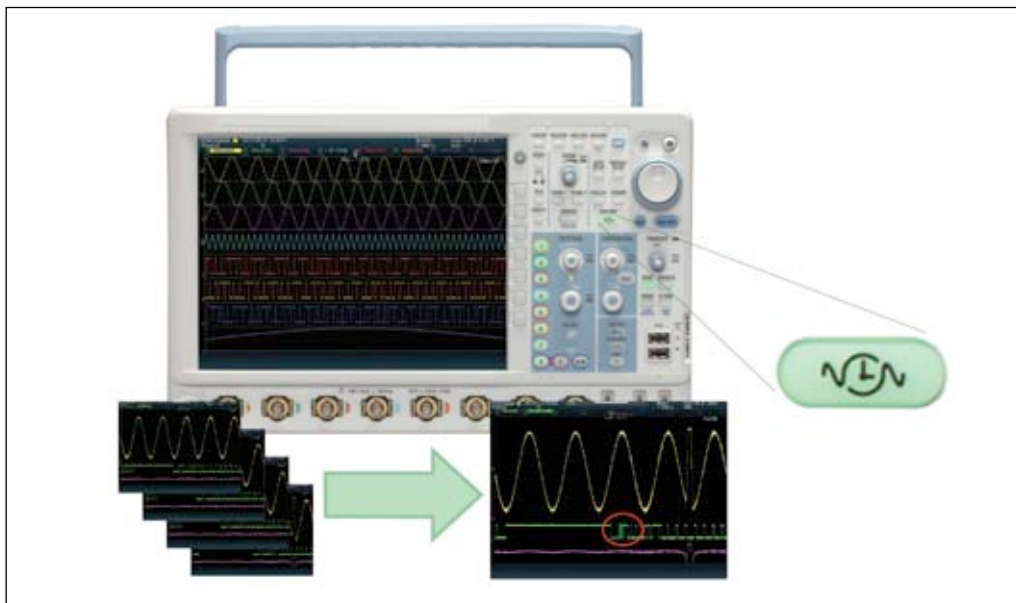

Fig. 2: Users can find abnormal signals that might otherwise be overlooked

fast-forwarded or rewind.

The history memory in combination with the advanced waveform search feature enables users to capture and see the details of anomalies on individual waveforms when their characteristics are still unknown (Fig. 2).

Advanced measurement and analysis features can include histogram and trending functions, digital filtering, zoom windows, user-defined mathematics, and serial bus analysis.

The combination of an eight-channel analogue input at 500MHz bandwidth with a 16bit logic input makes it possible to carry out comprehensive and efficient measurements on many captured waveforms without changing the probe connection. Moreover, by capturing logic and bus signals in the analogue domain, users can evaluate signal-quality effects such as surge and noise, which often have a damaging effect on overall system reliability. As an added benefit, the analogue channel is psychologically more friendly than a logic display for many oscilloscope users.

Fig. 3: Analogue IO and digital serial bus controller signals can be tested together

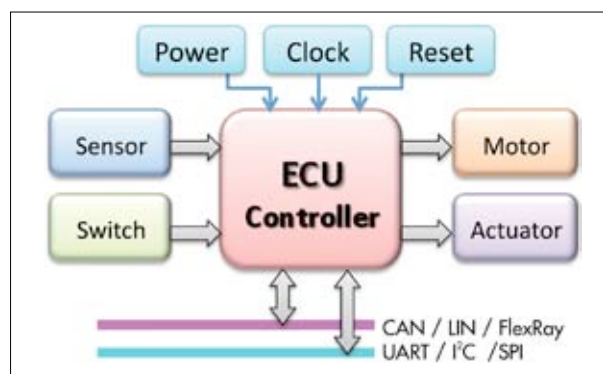

Serial bus testing

An eight-channel MSO can allow data from up to two serial buses (which can be Can, Lin, Flexray, I²C, SPI, uart or RS232) to be decoded and displayed in real time. A serial bus auto setup function can reduce the configuration work dramatically. Long memory enables long time measurements even at a fast sampling rate. This means that slow phenomena from mechanical equipment and fast electronic signals from the controller can be measured at the same time (Fig. 3).

For longer-term measurement or measurements with various physical signals along with Can bus data where the eight-channel requirement is exceeded, it is possible to use an additional instrument such as a scope-corder (a unit that combines the benefits of an oscilloscope with those of an oscillographic recorder) in combination with the MSO.

Formula One

Formula One is a sport that has transformed over the years into a billion dollar business. The sport has become so popular and with a wide global audience base it has become an attraction for hundreds of multinational companies. Grand prix racing has a long-standing history of providing technological developments, which are applicable not only to fast racing cars but also to the general automotive industry. One of these developments is the kinetic energy recovery system (kers), also known as regenerative braking, which is becoming one of the most widely discussed subjects in technical universities and automobile companies.

A Formula One car has kinetic energy when it runs, and when the brake is applied this kinetic energy is converted into a huge amount of heat energy, which would normally be wasted. This is not the case in a kers equipped car.

With the kers system (Fig. 4), when the driver brakes, this kinetic energy is converted to electrical energy. Formula One cars have an electric motor and batteries setup that is used to convert and store this energy in the car. The electric motor is mounted at one end of the engine crankshaft. When the brakes are applied, this electric motor captures a portion of the rotational

from the inverters or power supplies within the system.

Eight channels

To address these challenges, the latest eight-channel oscilloscopes (Fig. 1) provide comprehensive measurement capabilities for embedded, automotive, power and mechatronics applications.

The channels can be allocated as eight analogue channels or seven analogue channels plus one 8bit digital input. There are plans for such machines to have 16 more channels of logic to allow seven channels of analogue plus a 24bit digital input.

Not only do such oscilloscopes provide enough channels for analogue applications such as three-phase voltage and current measurements, they also enable users to view the actual waveform shape of digital signals. This helps the digital debug process as glitches are often caused by such things as noise and crosstalk which are invisible when viewing just 1s and 0s.

Some of these instruments have long memory (up to 62.5M points per channel and 125M points in interleave mode), allowing both long recordings and multiple waveforms to be acquired. A history memory function, which does not reduce the oscilloscope's waveform acquisition rate, can allow up to 20,000 previously captured waveforms to be saved in the acquisition memory, with any one or all of them displayed on screen for cursor measurements to be carried out. Waveforms can be displayed one at a time, in order, or automatically played back, paused,

force and converts the kinetic energy into electrical energy, which is stored in the battery bank. When the driver presses the kers or the boost button, the stored energy is converted back to kinetic energy, which gives the car additional power for a limited duration.

The kers system was first introduced in 2009 and only a few F1 teams used the technology. In 2010, kers was banned, but it was reintroduced in 2011. It is now being used by most of the F1 teams. Even though the kers system adds an extra 35kg weight which gives a challenge to the balance of the car, it does provide the driver approximately 60kW extra for up to 6.7s per lap. This extra capacity can be released in one go or at different points, which gives the driver an added advantage during overtaking or defending positions. The kers system is not only intended to help in overtaking and defending to create additional excitement in the race, but also it is a step towards bringing the sport close to greenness.

Testing kers

The F1 industry uses high-precision power analysers for the development and testing of kers system at both the R&D and production of stages. These power analysers (Fig. 5) are particularly suited to the measurement of electrical output, efficiency and losses in electric motors.

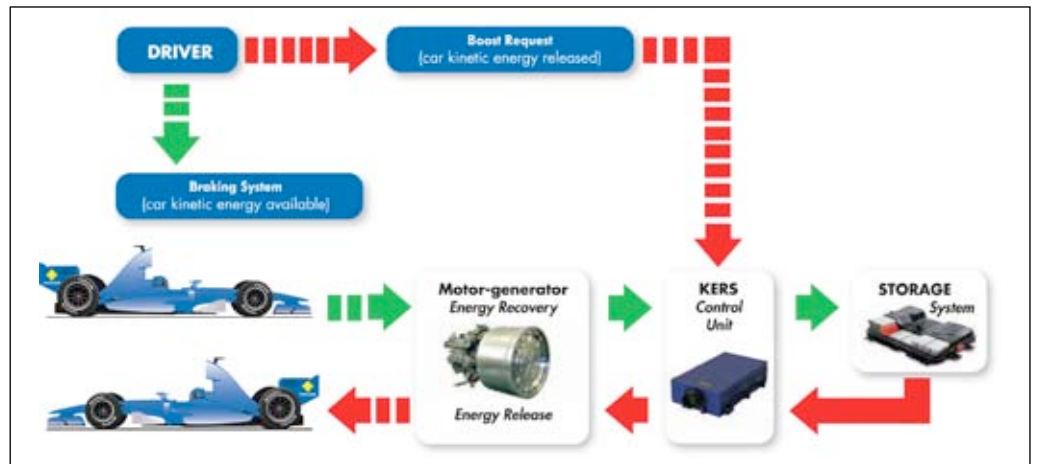

Fig.4: Schematic of the kers system as used in Formula One racing cars

The ability to connect six power inputs to a single analyser helps the users to evaluate the motor input and output efficiency. In addition, a motor evaluation function makes it possible to carry out simultaneous measurements of voltage, current and power as well as the rotation speed and torque changes. The input for torque and speed sensors helps in understanding the shaft power in electric motors, along with the direction of rotation. The six inputs of the analyser also help users to understand the battery characteristics by following the battery charge and discharge cycle and evaluating the inverter efficiency between the input and output.

Conclusion

These are just two areas in which advances in automotive systems have

posed new challenges for the test and measurement sector, but most of these challenges are being addressed by the latest generation of test instruments.

As the automotive industry develops still further into the realms of electric and hybrid vehicles, electrical power trains and green initiatives to optimise performance and efficiency, so the test industry will respond by continuing to provide the appropriate measurement tools. ●

All three authors work for Yokogawa in Europe and Africa: Clive Davis is manager for test and measurement marketing; Kelvin Hagebeuk is product marketing manager for scope-corders and portable test instruments; and Hafeez Najumudeen is product marketing manager for power meters and analysers

Fig. 5: Precision power analysers are ideally suited to the testing of kers and related systems in modern racing cars

